

PNEUMATIC ROLLER

SR30T-3

Ready for super heavy-duty roadwork

- ▶ Engine model: Shangchai D6114ZG6B
- ▶ Rated power: 132 kW/2000 rpm
- ▶ Max. operating weight: 30.0 t

Product features

With a powerful, fuel-efficient Shangchai engine, international water pump and greater compacting power plus efficient coverage for asphalt projects, the SR30T-3 delivers real roadwork power. A five-gear system ensures accurate water application, and the exterior design incorporates indented stairs to the cab to enhance operator safety.



SHANTUI

VALUE THAT WORKS

Shantui Construction Machinery Co., Ltd.

ADDRESS:

No. 58, G327 Highway
Jining City, Shandong, CHINA

TEL: +86-537-2909369

FAX: +86-537-2311219

EMAIL: trade@shantui.com

PNEUMATIC ROLLER

SR30T-3

Technical specifications:

Overall length: 5060 mm



Minimum turning radius: 9000 mm

Overall width: 2845 mm

Fuel capacity: 195 L

Overall height: 3480 mm

SR30T-3

WEIGHT AND DIMENSIONS			
	Weights	Minimum operating weight	12900 kg
		Metal ballast	15500 kg
		Water ballast	1600 kg
		Maximum working weight	30000 kg
	Compaction characteristic	Working width	2365 mm
		Tire distance	510 mm
		Ground pressure	270~480 kPa
		Wheelbase	3840 mm
		Front/rear tire overlap	70 mm
		Front tire oscillation	±50 mm
Tires	Number of tires, front/rear	Front: 4/rear: 5	
	Tire size	13/80-20	
ENGINE AND DRIVE TRAIN			
	Engine	Make & model	Shangchai D6114ZG6B
		Type	Turbocharged
		Fuel	Diesel
		Cooling	Water
		Number of cylinders	6
		Rated power	132 kW
		Rated speed	2000 rpm
	Drive train	Minimum ground clearance	290 mm
Maximum climbing ability		20 %	
Forward speed		I	0~8 km/h
		II	0~16 km/h
Reverse speed	I	0~8 km/h	
CABIN & CONTROLS			
	Electrical system	DC, negative ground	24 V
		Alternator	28 V, 55 A
	Brakes	Service brake	Caliper dry disc
		Parking brake	Spring-loaded/mechanical
	Steering	Steering system	Hydraulic
		Steering method	Articulation
Steering angle (Grad)		±33°	
Steering radius		8.5 m	

OVERALL DIMENSIONS

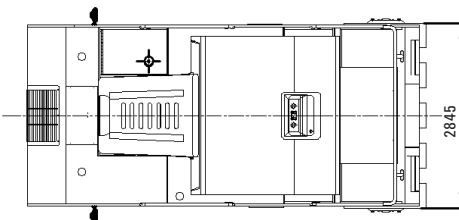
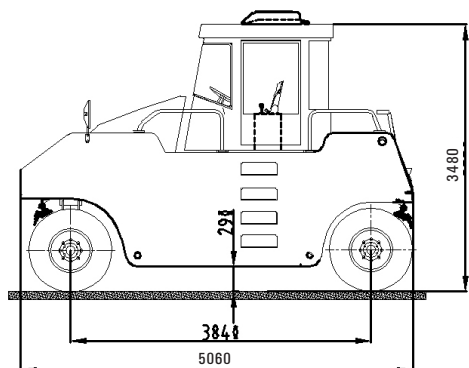

▶ THE SPECIFICATIONS ARE SUBJECT TO CHANGE WITHOUT NOTICE. THE PICTURES MAY INCLUDE OPTIONS. THE ACTUAL COLOR & APPEARANCE OF THE PRODUCT MAY DIFFER FROM WHAT IS SHOWN.